



Talley® Manufacturing, Inc.

9183 Old No. 6 Hwy

PO Box 369

Santee, SC 29142

803-854-5700

www.TALLEYRINGS.com

DETACHABLE SCOPE RING ASSEMBLY INSTRUCTIONS

Assembly instructions:

1. Disassemble all parts of scope ring. Take care to identify all included parts.
2. Affix Base plate (#D) to rifle unless rifle is equipped with Dovetail Receiver.
3. Place parts (#A) & (#B) around scope tube.
4. Insert screws (#1) in bottom of rings and tighten to 25in/lbs.

ATTENTION: THERE SHOULD BE NO GAP AT BOTTOM OF RING.

5. Insert springs (#4) in screw holes as pictured in Diag. 1
6. Place Locking Plate (#C) over springs and finger tighten with Screw (#3) or with (optional) Lever Assembly.
7. Repeat with 2nd ring assembly.
8. Place the scope rings on Bases (#D) or Dovetail Receiver. Tighten the Locking Plate to 30in/lbs. This will secure the rings. You can square up the scope reticle and adjust for proper eye relief.
9. Insert top screws (#2) and tighten to 20in/lbs.

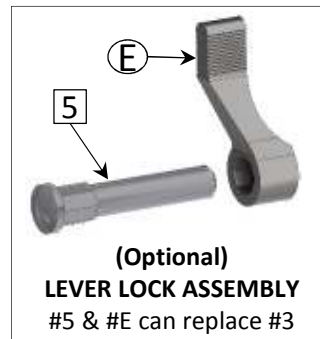

Parts List

- #A – Scope ring 1
- #B – Scope Ring 2
- #C – Locking Plate
- #D – Base Plate
- #E – Lever (Optional)
- #1 – #6-48x3/8" Torx
- #2 – #6-48x5/16" Torx
- #3 – #10-32x3/4" Torx
- #4 – Spring
- #5 – Lever Bolt (Optional)

Note: The levers should point toward one another. This can be gained by rotating the lever on it's screw while screw is finger tight.

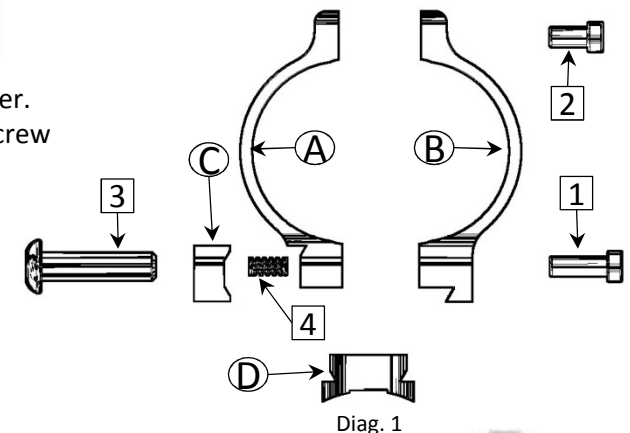

Disclaimer: Always make sure your torque wrench is calibrated. Talley Mfg. is not responsible for damage caused to scopes due to over-torquing.

KEEP ALL ASSEMBLY NUMBERS, APPEARING ON THE BOTTOM OF THE RING, TOGETHER.

For Technical Assistance, please call Talley, Mfg. @ 803-854-5700

Copyright 2017, Talley Manufacturing, Inc.

